



BAS1020

Hardware Manual

Version 1.0

BAS1020 Overview:	3
Size and measurements:.....	4
Power:.....	4
Modules:	4
Ethernet:	5
USB OTG	5
LEDs:.....	5
Top - Green:.....	5
Middle - Green:	5
Bottom - Red:	5
Reset switch:.....	5
Internal Option Modules.....	7
BAS9_M485 RS485 module.....	7
BAS9_MBUS M-Bus module.....	8
BAS9_KNX KNX module.....	8
BAS9_LON LON module.....	9
COMM module:	10
BAS920COMM Contains 2 communication channels that can be used the following way:.....	10
I/O:.....	12
Mainmodule:.....	12
Analog input module (AI):	13
Analog output module (AO):.....	14
Digital input module (DI):.....	15
Digital output module (DO):	16
Digital input/output and M-Bus module (DIOM):	17
BUS Expansion modules (EXT):	19
TCP/IP ports:	20
Firmware, manuals, tools etc:.....	20
Firmware setup:	20

BAS1020 Overview:

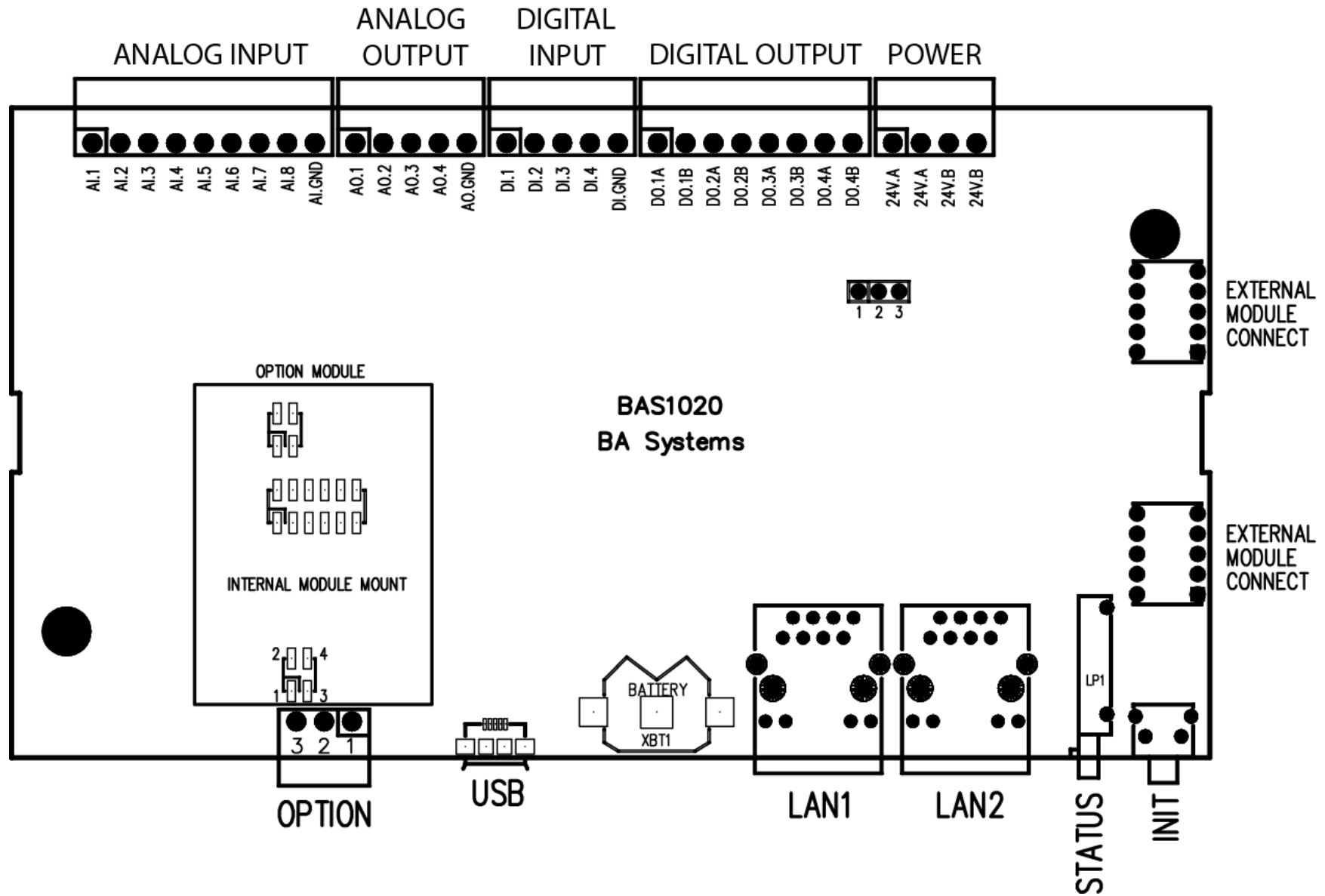

Size and measurements:

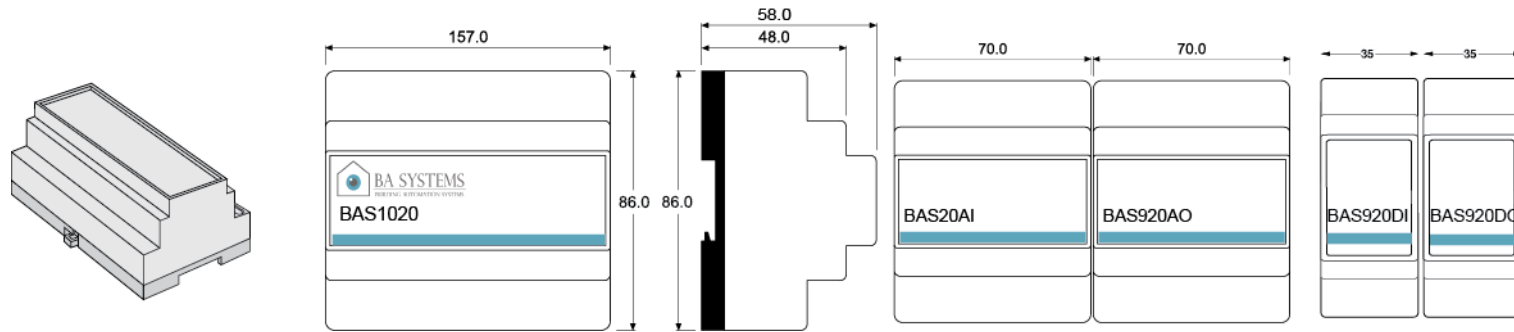

Power:

Use a 24VAC with a tolerance of 10% or a DC supply with minimum voltage of 15V and maximum of 35V. The power supply/transformer must be able to deliver a least 6W without modules and at least 30W with all modules. The 2 input terminals with the label **24V.A** are connected, as well as **24V.B** terminals are connected. This power input is not sensitive to polarity, but for the sake of having structured power cabling, please use 24V.A as the positive terminal and 24V.B as the negative terminal.

NOTE: The USB and OPTION port connections include a GND reference extracted from the controller internal circuit. This will not have the same potential as the GND from the device to be connected. So to avoid destructive GND equalizing currents it is required to use galvanic isolated supplies between devices communicating over these interfaces.

Modules:

Extra modules are numbered from left to right. Modules can only be attached to the right side of the BAS1020. A maximum of 15 modules can be used. The COM module is not included in this count and must be placed first in the chain.

If two extra DI modules are mounted, the module to the left will have channel numbers 9-16 and the following module 17-24. This is also true for the I/O types that only have 4 ports on the BAS1020 main module. For these I/O types the channels from 5-8 are invalid and will deliver invalid measurements.

WARNING: The modules are **NOT** hot pluggable. The power supply for the BAS1020 **MUST** be disconnected before any changes to the module configuration.

Ethernet:

10/100 Mbps standard ethernet, can auto detect if the cable is crossed, it is thus not necessary with a crossed cable even if the BAS1020 is connected directly to a PC without a switch or hub. The BAS1020 is factory configured with fixed IP-address.

The default setup is: IP 192.168.1.250, Netmask 255.255.255.0, Gateway 192.168.1.1. The BAS1020 has a built-in switch

USB OTG

The BAS1020 can function as a USB 2.0 compatible USB Device that can be connected to a PC for communication. The BAS Tool program need to be installed as the USB to Serial driver is in this installation package.

LEDs:

Top - Green:

Blinking slowly: The system is alive

Middle - Green:

Blinking: Activity on RS232/RS485/USB/Ethernet

Bottom - Red:

Normally off, if blinking an error has occurred, please check the system log. If the LED is permanently on the system is running without the script enabled.

During startup or during an update the LEDs blink, but after ca 30 seconds the LEDs take function as described above. If all 3 LEDs blink a reboot is pending.

Reset switch:

This switch has two purposes:

- 1) Making the system go into Script Disabled mode. This is done by pressing the button when the two Green LEDs are toggling repeatedly during startup. In this state the IP setup is temporarily changed back to factory defaults. This will remain in effect until next reboot.

- 2) Making the system reboot. This is done by pressing the button for approx. 10 seconds. When the controller has accepted the reboot request all 3 LEDs will start blinking simultaneously. Then, and only then, release the button and the reboot will commence

Please note:

This switch **must not be touched** during power on or after reset has been signaled via the 3 LEDs blinking. If this is done accidentally the system will need to be powered off and back on again to function normally

Internal Option Modules

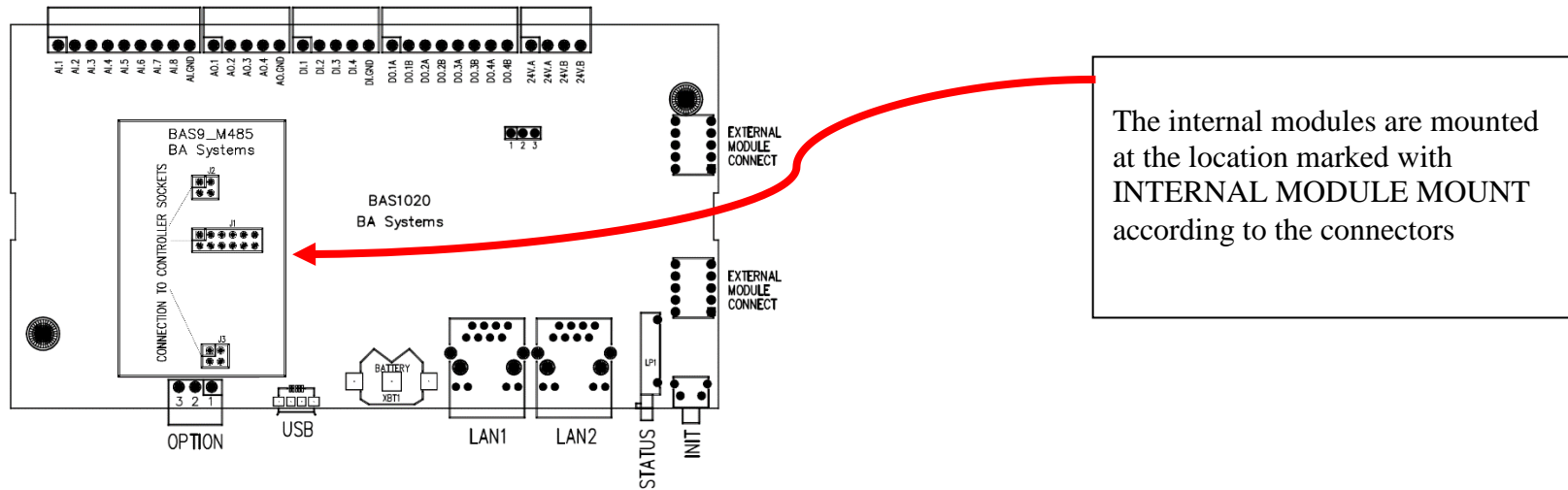

The internal slot can be empty or mounted with either M-Bus, RS485, KNX or LON. The modules are normally mounted from the factory. If re-configuration is required please be very careful when mounting the module as a misaligned connection can damage the BAS1020 and/or the module.

BAS9_M485 RS485 module

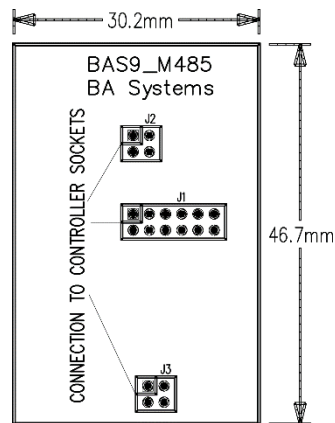

The pin-out is as follows:

Terminal pin	RS485
1	A (PLUS)
2	GND
3	B (MINUS)

BAS9_MBUS M-Bus module

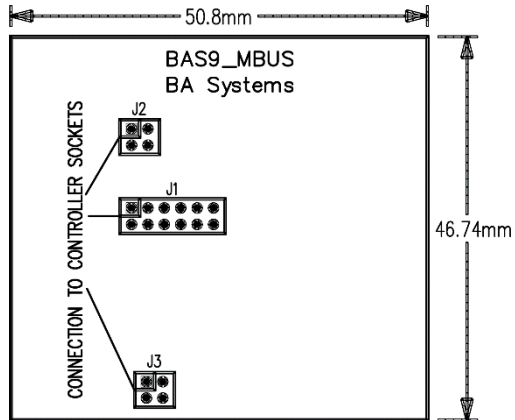

The pin-out is as follows:

Terminal pin	MBUS
1	BUS PLUS
2	NC
3	-24V (BUS MINUS)

BAS9_KNX KNX module

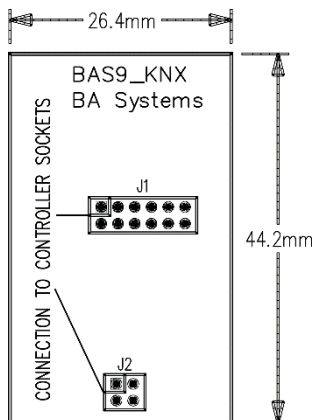

The pin-out is as follows:

Terminal pin	KNX
1	BUS +
2	KEY (Short to BUS- for configuration mode)
3	BUS -

BAS9_LON LON module

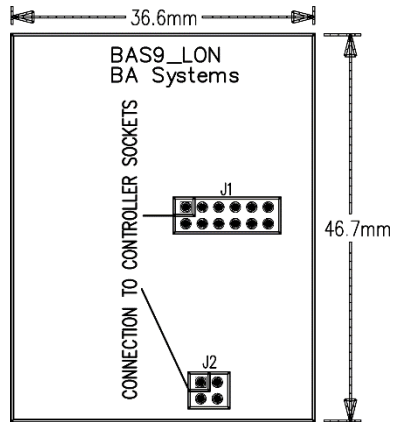

The pin-out is as follows:

Terminal pin	LON
1	NET A
2	NC
3	NET B

Bus interfaces with differential signaling (all except MBUS) must use twisted pair cabling. The differential pair must use one wire pair in the cable. I.e. it must not be split between cable pairs.

COMM module:

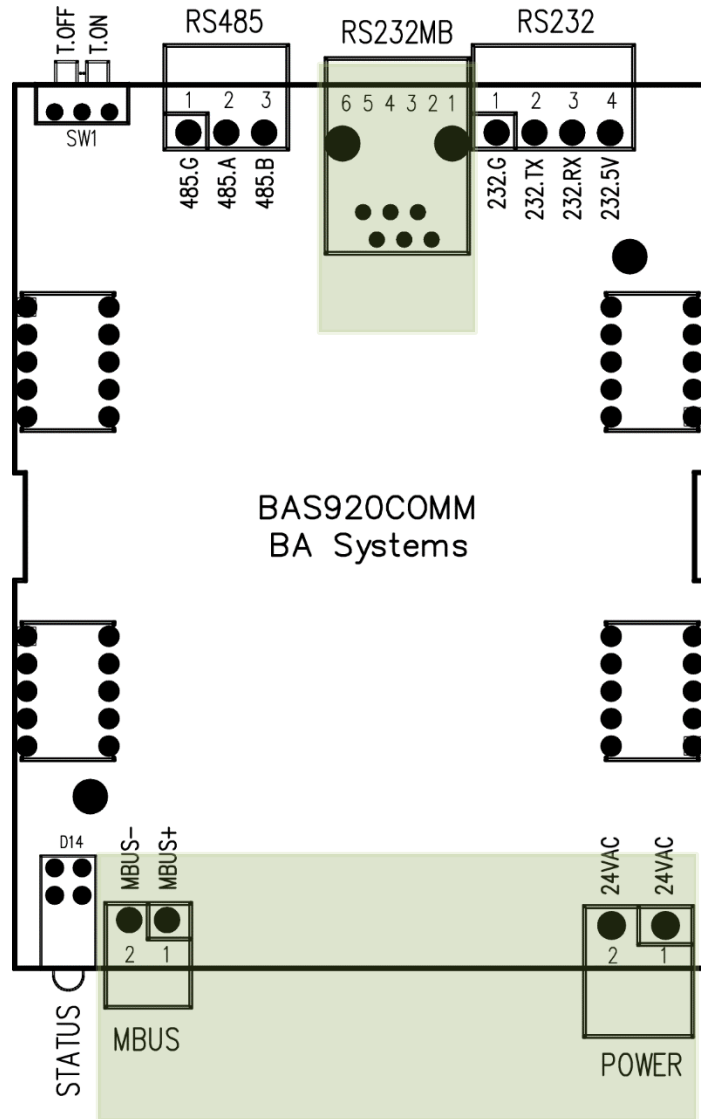

BAS920COMM Contains 2 communication channels that can be used the following way:

MBUS

M-Bus and RS232 to M-Bus with the following connections:

RS232MB connector pinout

Pin no	Signal
1	5V
2	5V
3	TXD
4	RXD
5	GND
6	GND

MBUS connector pinout

Pin no	Signal
1	+
2	-

If the RS232MB is to be used by other software to read or configure M-Bus units a 24VAC must be connected to the module. Also the module **must** be connected to a BAS1020 that **must** be turned on. If the BAS1020 is already setup to communicate with M-Bus unit, this communication should be stopped in order for it not to interfere. This must be done using the BAS Tool to operate the Console interface. When the console interface is ready, the following commands can be issued: 'master mbus stop' to stop any communication from the BAS1020. When done, the 'master mbus start' command must be entered or the BAS1020 can be reset. This step is only required if the script in the BAS1020 uses M-Bus. The RS232MB cannot be used for other purposes.

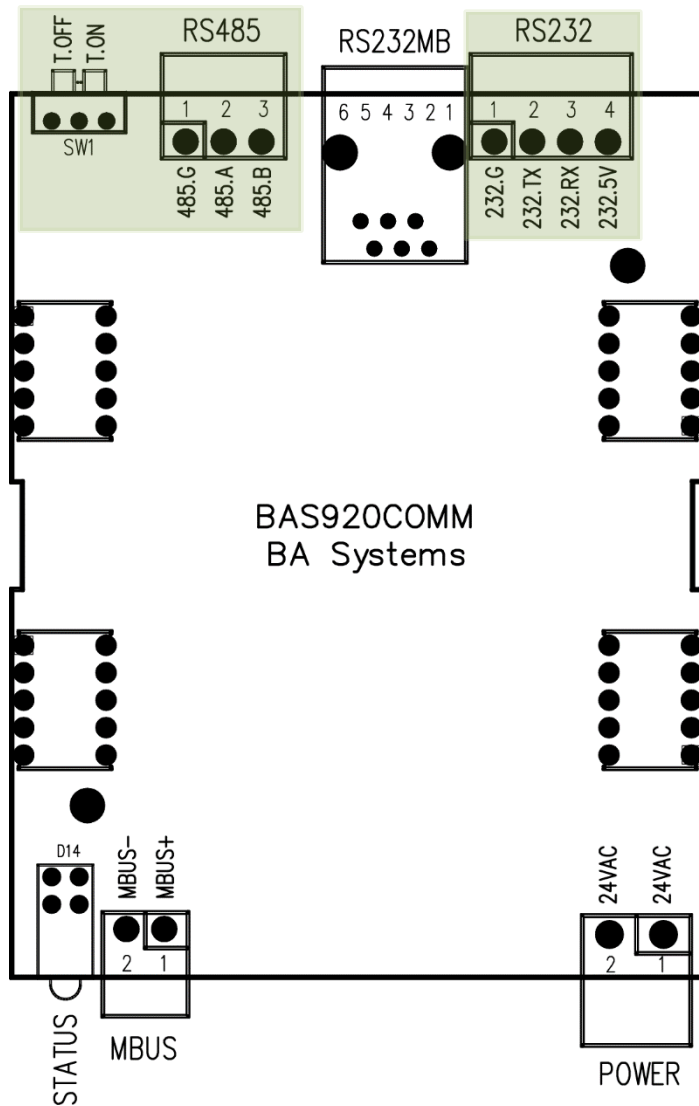

RS485

RS232 interface is parallel to the RS485 interface. This means that either the RS232 or the RS485 can be used – but not at the same time – or data will be corrupted.

Bus termination on RS485 can be configured on SW1. In position **T.OFF**, termination will not be applied, and in position **T.ON**, a 120 ohm resistor will be connected between **485.A** and **485.B** signals.

The connections are as follows:

RS232 connection

Pin no	Signal
1	GND
2	TXD
3	RXD
4	5V

RS485 connection

Pin no	Signal
1	GND
2	RS485.A (+)
3	RS485.B (-)

Power connection

Pin no	Signal
1	24VAC
2	24VAC

The 5V power supply on the RS232 was used for legacy equipment as should NOT be used. The COMM Module does not add to the module count (max 15), but ***must*** be placed first in the module chain.

I/O:

Mainmodule:

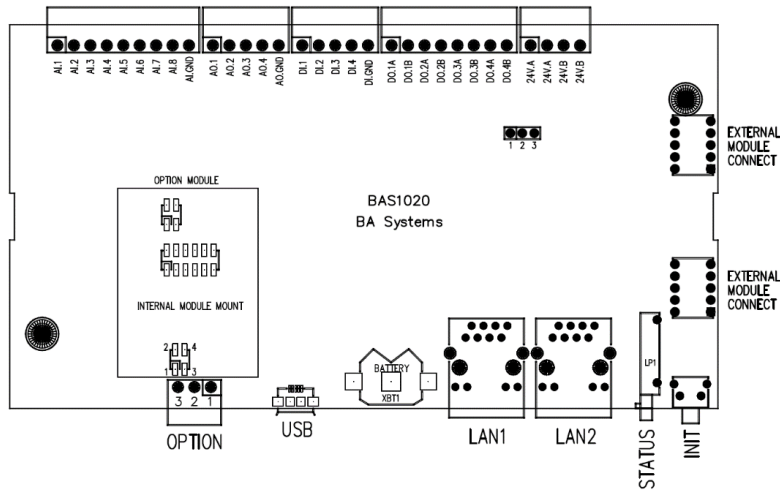

Analog output: 0-10V
Analog input: 0-20 mA
0-5 V
0-1600 ohm (PT1000)
0-44500 ohm
Digital outputs: 24VAC/DC 1A.
Please note that these are solid state relays – this means that they **cannot** handle overload
Digital inputs: Must be connected to potential free contacts

Note: The analog inputs are self-configuring. This means that the script determines how the port is configured. This has the further implication that an analog input can inadvertently be harmed by connecting it to a 4-20 mA signal and subsequently programming it to a PT1000 input. This might damage the port.

BAS1020 is mounted on a DIN36 rail and has 8 analog inputs, 4 analog outputs, 4 digital inputs and 4 digital outputs. For a description of each type please see the BAS920AI, BAS920AO, BAS920DI and BAS920DO below

Each analog input channel is connected with two wires, the first channel is connected to AI.1 and AI.GND, where AI.1 is the positive terminal.

Each analog output channel is connected with two wires, the first channel is connected to AO.1 and AO.GND, where AO.1 is the positive terminal.

Each digital input channel is connected with two wires, the first channel is connected to DI.1 and DI.GND.

Each digital output channel is connected with two wires, the first channel is connected to DO1.A and DO1.B.

Because all modules including the BAS1020 itself are galvanically isolated from each other, the ground terminals on a module is not connected internally with any other module.

Channel numbering are AI 1..8, AO 1..4, DI 1..4 and DO 1..4

Analog input module (AI):

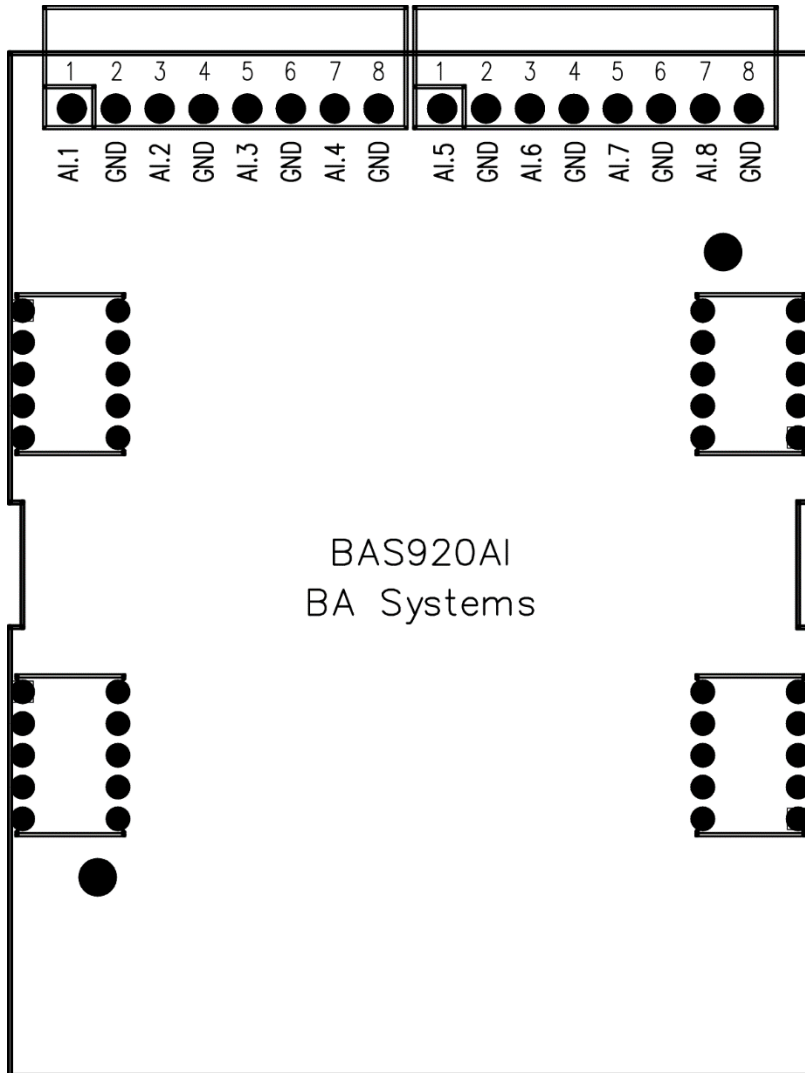

BAS920AI is mounted on a DIN36 rail and has 8 analog inputs that can be programmed individually. Each channel can be configured as follows:

- 0-1620 ohm
- 0-44500 ohm
- 0-10V
- 0-20mA

The configuration for each channel is determined by the BAS1020's built-in programming language. No jumpers are needed/used.

The module is connected to the BAS1020 via two 10 poled interconnectors. Please note that the power must be *off* when connecting/disconnecting modules on the bus. The module orientation is determined by ensuring that the top label on each module/controller have the same orientation.

Each channel is connected with two wires, the first channel is connected to AI.1 and GND, where AI.1 is the positive terminal. Please note that the GND terminals on the module are internally connected. Because all modules are galvanically isolated from each other, the ground terminals on a module is not connected internally with any other module.

Channel numbering are continuous for BAS920AI modules. The channel on the first BAS920AI module are numbered 9 to 16. For the next BAS920AI module, the channels are numbered 17 to 24. This is true, even if other module types are mounted between BAS920AI modules.

Analog output module (AO):

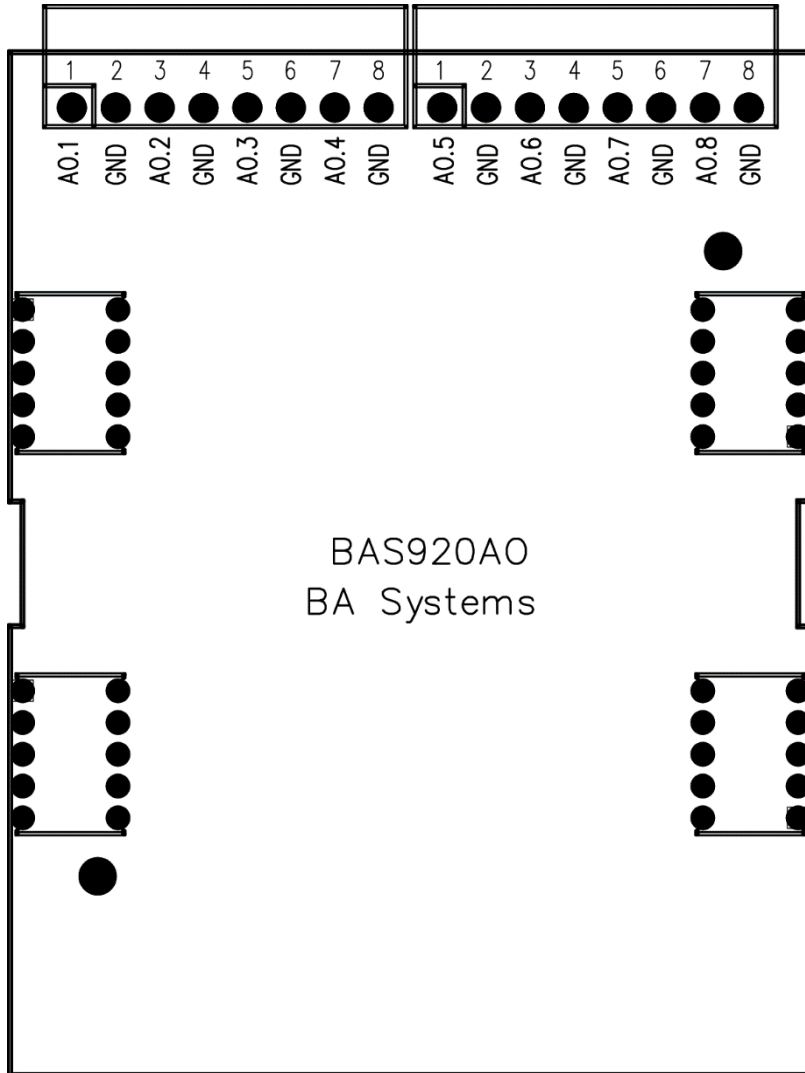

BAS920AO is mounted on a DIN36 rail and has 8 analog outputs. Each channel has the following configuration:

- 0-10V

No jumpers are needed/used.

The module is connected to the BAS1020 via two 10 poled interconnectors. Please note that the power must be *off* when connecting/disconnecting modules on the bus. The module orientation is determined by ensuring that the top label on each module/controller have the same orientation.

Each channel is connected with two wires, the first channel is connected to AO.1 and GND, where AO.1 is the positive terminal. Please note that the GND terminals on the module are internally connected. Because all modules are galvanically isolated from each other, the ground terminals on a module is not connected internally with any other module.

Channel numbering are continuous for BAS920AO modules. The channel on the first BAS920AO module are numbered 9 to 16. For the next BAS920AO module, the channels are numbered 17 to 24. This is true, even if other module types are mounted between BAS920AO modules

Digital input module (DI):

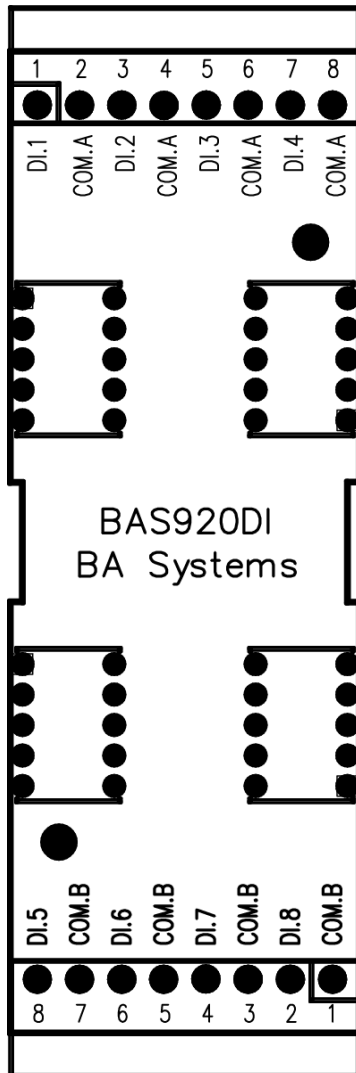

BAS920DI is mounted on a DIN36 rail and has 8 digital inputs. Each channel has the following configuration:

- Connects to a potential free contact set

No jumpers are needed/used.

The module is connected to the BAS1020 via two 10 poled interconnectors. Please note that the power must be *off* when connecting/disconnecting modules on the bus. The module orientation is determined by ensuring that the top label on each module/controller have the same orientation.

Each channel is connected with two wires, the first channel is connected to DI.1 and COM.A.

Please note that COM.A terminals are internally connected, and so are the COM.B terminals. COM.A and COM.B are not internally connected.

Because all modules are galvanically isolated from each other, the COM.A and COM.B terminals on a module are not connected internally with any other module.

Channel numbering are continuous for BAS920DI modules. The channel on the first BAS920DI module are numbered 9 to 16. For the next BAS920DI module, the channels are numbered 17 to 24. This is true, even if other module types are mounted between BAS920DI modules

Digital output module (DO):

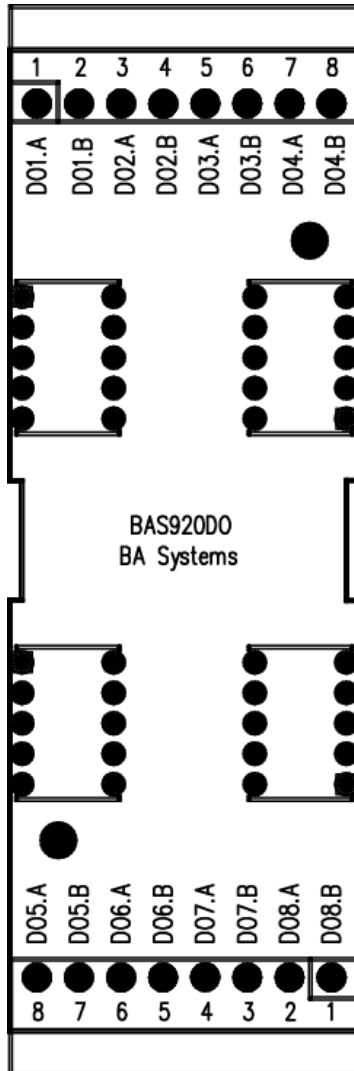

BAS920DO is mounted on a DIN36 rail and has 8 digital outputs. Each channel has the following configuration:

- Potential free contact set, rated to 2A 24VAC/VDC

No jumpers are needed/used.

The module is connected to the BAS1020 via two 10 poled interconnectors. Please note that the power must be *off* when connecting/disconnecting modules on the bus. The module orientation is determined by ensuring that the top label on each module/controller have the same orientation.

Each channel is connected with two wires, the first channel is connected to DO1.A and DO1.B

Please note that no channels are internally connected. Because all modules are galvanically isolated from each other, the terminals on a module are not connected internally with any other module.

Channel numbering are continuous for BAS920DO modules. The channel on the first BAS920DO module are numbered 9 to 16. For the next BAS920DO module, the channels are numbered 17 to 24. This is true, even if other module types are mounted between BAS920DO modules

Digital input/output and M-Bus module (DIOM):

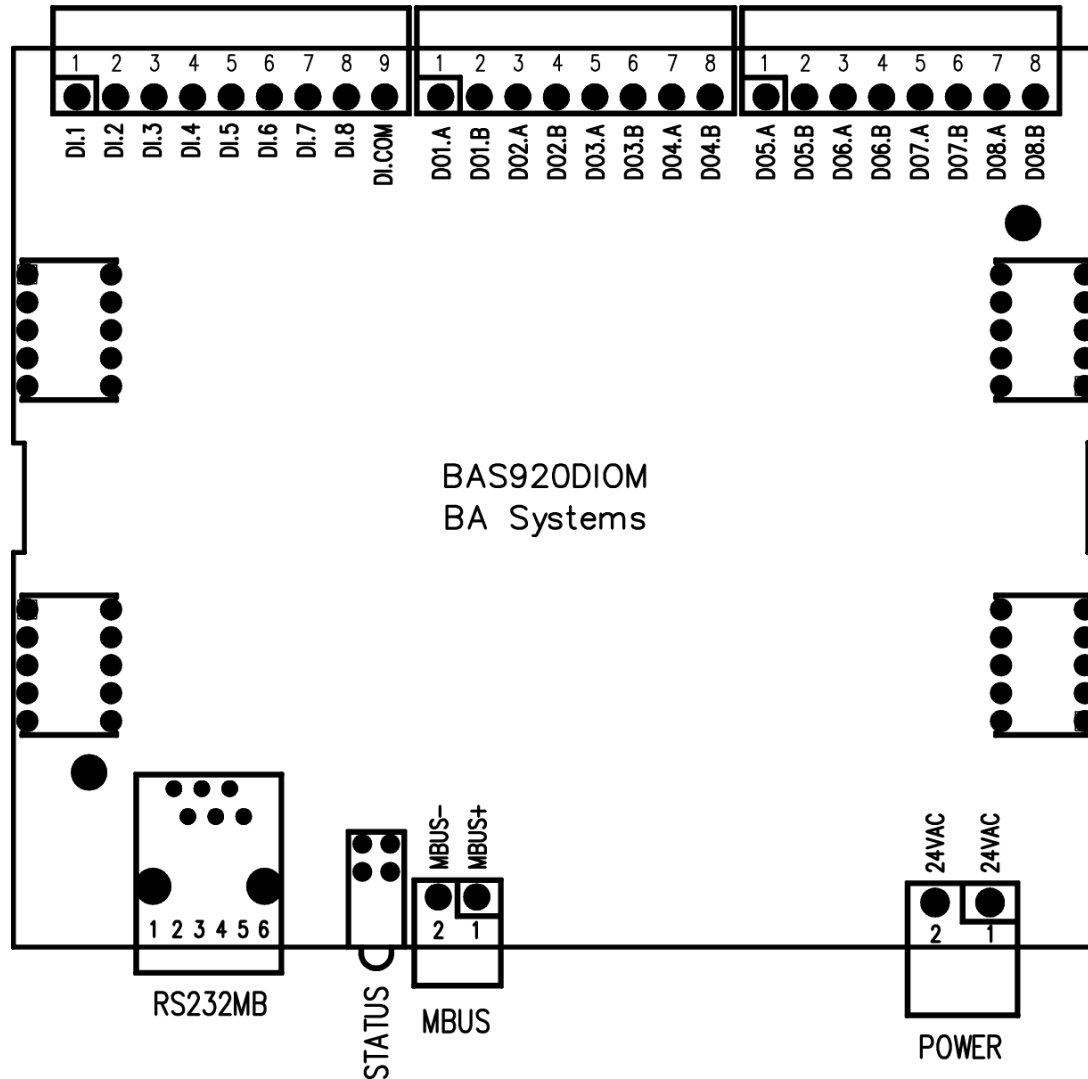

BAS920DIOM is mounted on a DIN36 rail and has 8 digital inputs, 8 digital outputs and an M-Bus. The module is a merge of one BAS920DI, one BAS920DO and an M-BUS interface. See I/O description in previous sections.

The module is connected to the BAS1020 via two 10 poled interconnectors. Please note that the power must be *off* when connecting/disconnecting modules on the bus. The module orientation is determined by ensuring that the top label on each module/controller have the same orientation.

Channel numbering are continuous for the BAS920DO module part. The channel on the first BAS920DO module are numbered 9 to 16. For the next BAS920DO module, the channels are numbered 17 to 24. The same is true for the BAS920DI part.

Please note that BAS1020 can only have one BAS920DIOM connected to the module expansion bus.

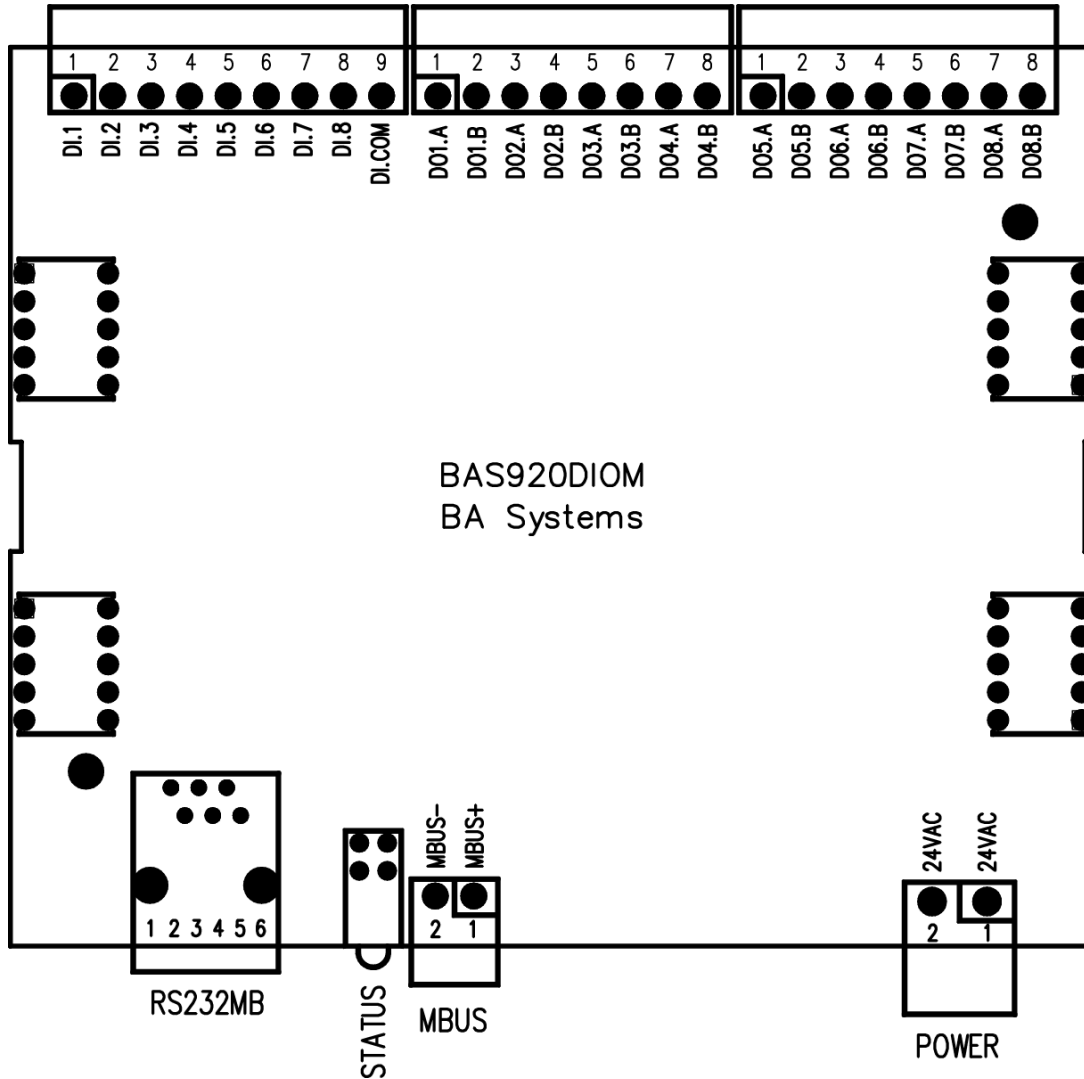

The M-Bus and the RS232 to M-Bus have the following connections:

RS232MB connection

Pin no	Signal
1	NC
2	NC
3	TXD
4	RXD
5	GND
6	GND

MBUS connection

Pin no	
1	+
2	-

POWER connection

Pin no	Signal
1	24VAC
2	24VAC

If the RS232MB is to be used by other software to read or configure M-Bus units the 24VAC must be connected to the module, and the module **must** be connected to a BAS1020 that **must** be turned on. Additionally, the BAS Tool console interface must be used to write 'master mbus stop' to stop any communication from the BAS1020. When done, the 'master mbus start' command must be entered or the BAS1020 reset. This step is only required if the script in the BAS1020 uses M-Bus. The RS232MB cannot be used for other purposes.

BUS Expansion modules (EXT):

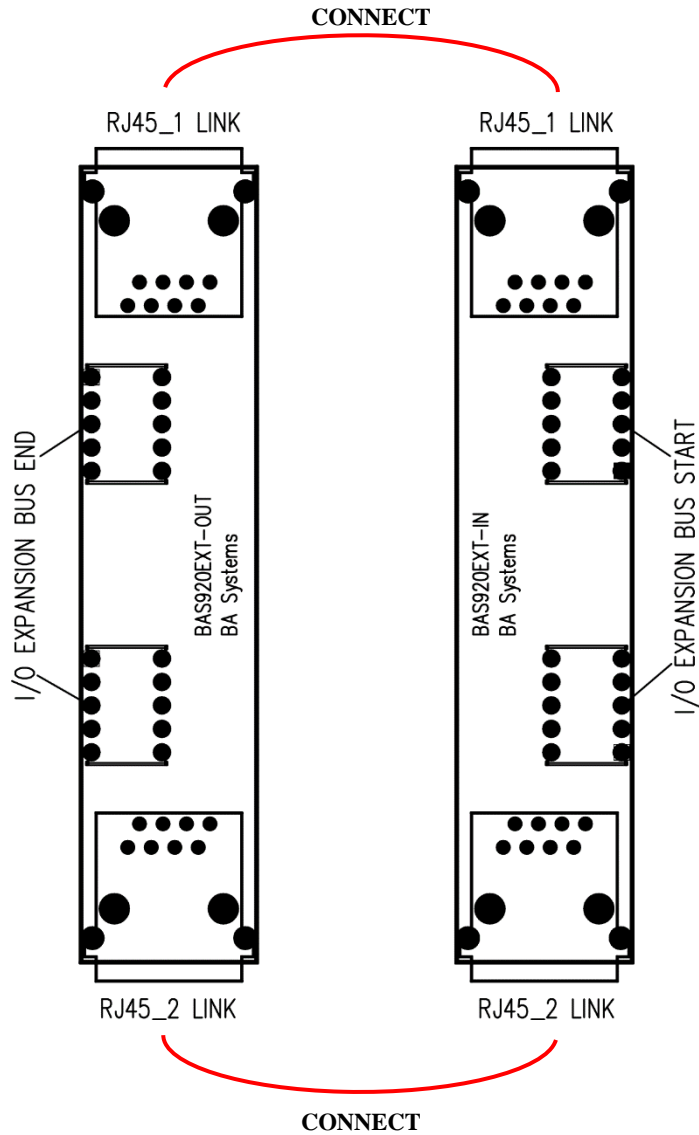

BAS920EXT modules are intended for extending the I/O expansion bus to a second DIN36 rail.

The BAS920EXT-OUT module terminates the bus on a DIN rail. Then by connecting standard RJ45 CAT5 cabling (or better) between this and a BAS920EXT-IN module on the next DIN rail, power and signaling are extended. So the BAS920EXT-IN will initiate the Expansion bus on the next DIN36 rail.

Please note that modules with communication interfaces must be located on the first DIN rail.

TCP/IP ports:

Used ports for TCP and UDP.

Name	Port	Type	Description	Connections
SMTP	25	TCP	Transmission of e-mails	1
Slave	75	UDP	BAS Tool in UDP mode	Several
HTTP	80	TCP	Browser and BAS for Web	6
Poll	90	UDP	BAS Series in Slave mode for substation interface	Several
Subscribe	147	UDP	BAS Series in UDP mode for reception of data from other substations	Several
Publish	146	UDP	BAS Series in UDP mode for transmission of data to other substations	Several
Relay	838	TCP	BAS Relay services	1
Message	837	TCP	BAS Message Services	1

Firmware, manuals, tools etc:

Updated firmware, manuals and current tools can be found on the homepage.

Firmware setup:

This is normally done via BAS Tool. BAS1020 must be restarted for the new firmware to become active.